

Lead Glass Disks

Lead Glass Disks are used in applications where there is a risk of X-ray exposure through an unshielded viewport. The lead glass disk is attached to the air side face of UHV viewports via a fixing ring which is bolted directly to the viewport.

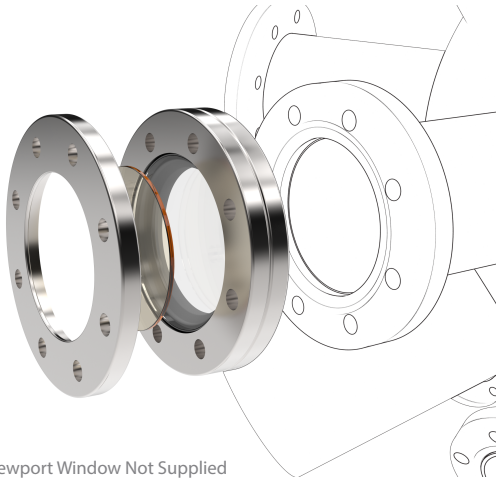

Product Overview

- Lead glass disk kit can be fitted to any viewport of the appropriate size.
- Supplied with fixing ring and lead glass disk.
- Lead glass disk cannot be removed without breaking vacuum for added health and safety.
- The lead glass disks are 6mm thick and have a lead thickness equivalent of 1.5mm for X-ray sources up to 150 kV.
- Maximum bake temperature 450 °c - dependent on bakeout temperature of the viewport.

Lead Glass Disk with Fixing Ring		
DN Type	OD Flange Size (mm)	Order Code
DN16CF	34	VPZ16LGDR
DN38CF	70	VPZ38LGDR
DN64CF	114	VPZ64LGDR
DN100CF	152	VPZ100LGDR
DN150CF	203	VPZ150LGDR

(1) Lead thickness equivalent for X-ray sources with voltages up to 150 kV.

It is the responsibility of the user to check for radiation leakage from the system when using viewports fitted with lead glass disks.

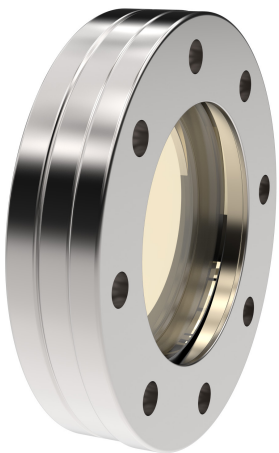

Image shows compact assembly



*Viewport Window Not Supplied