

## RP100 SEAL REPLACEMENT INFORMATION

Use in conjunction with manual

- 1) Remove the RP100 from system
- 2) If fitted, remove the handwheel / motor assembly, this is held on to the body via cap head screws.
- 3) Remove Index Dial (3)
- 4) Remove the Bearing Clamp Ring (1)
- 5) Lift off Rotating Flange (6)
- 6) Remove seals and spacers
- 7) Clean out with Isopropanol
- 8) Wipe over new seals with isopropanol to remove loose surface
- 9) Fit seals and spacers
- 10) Fit Rotating Flange and clamp ring.
- 11) When fully assembled, the turning torque should be between 8Nm & 18Nm.
- 12) If possible, test on a leak checker with the interspaces pumped

**Bearing**



Bearing

**Clamp Ring & Bearing**



Base Flange

Rotating Clamp Ring

**Base Flange Assembly**



Clamp Ring

**Seals & Spacers**

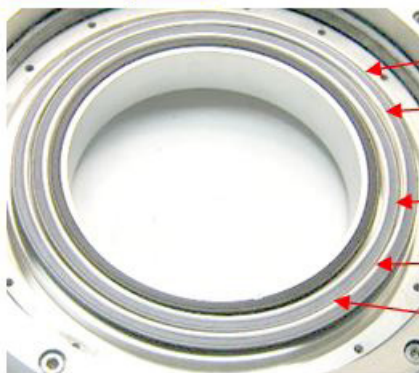

Seal Large XSMS08

Seal Spacer  
Rotating Flange

Seal Medium XSMS09

Seal Spacer

Seal Small XSMS10

**Main Bearing Assembly**



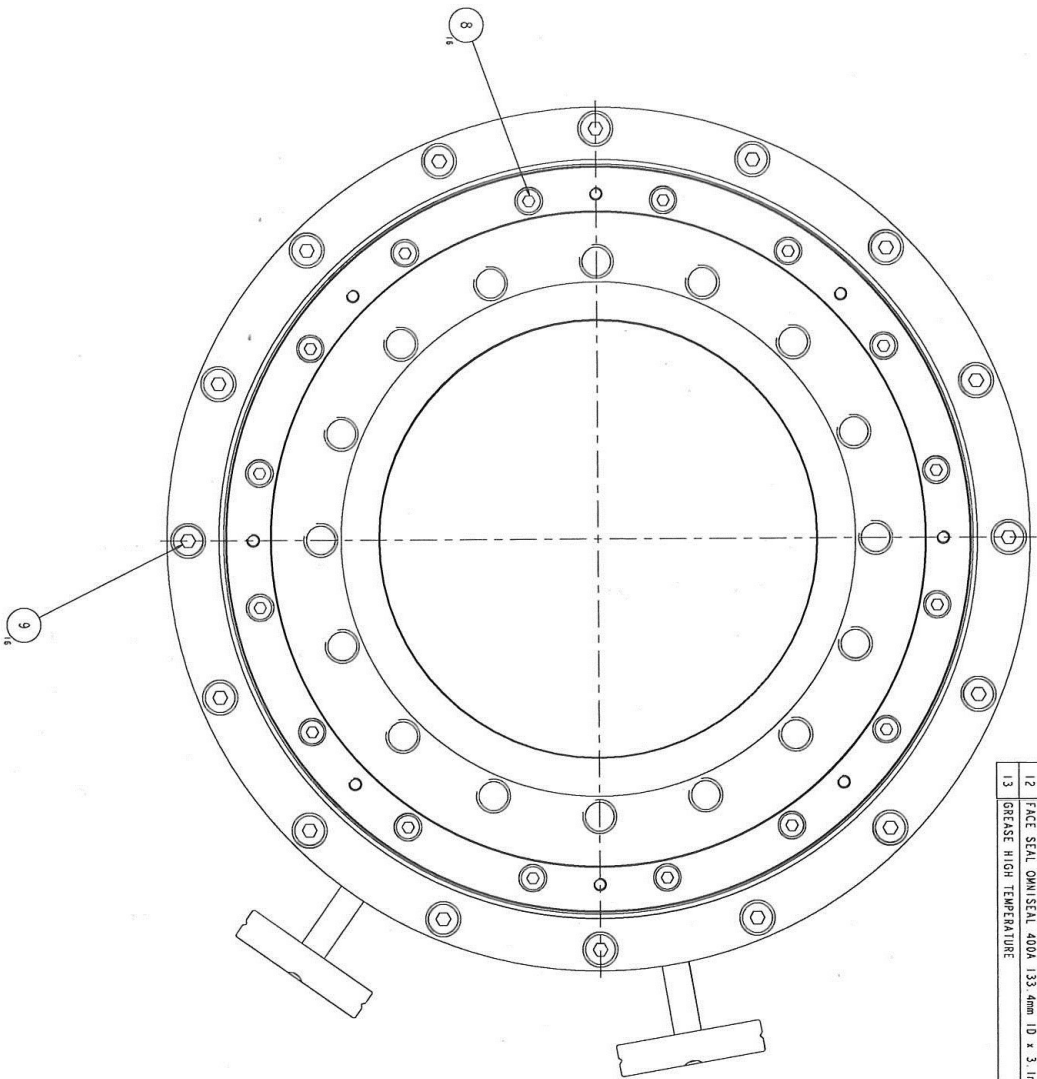

ITEM	DESCRIPTION	QTY	REMARKS
1	BEARING CLAMP RING BASE FLANGE	1	
2	BEARING CLAMP RING ROTATING FLANGE	1	
3	SEAL SPACER A	1	
4	SEAL SPACER B	1	
5	BASE FLANGE ASSEMBLY	1	
6	ROTATING FLANGE	1	
7	BEARING 4 POINT CONTACT 170 x 154 x 8	1	
8	M3 CAP HEAD SCREW 20 LONG	16	
9	SCREW, CAP HEAD, M4 x 16 ST. STEEL	16	
10	FACE SEAL OMNISEAL 400A 109mm ID x 3.1mm SECTION	1	
11	FACE SEAL OMNISEAL 400A 120.7mm ID x 3.1mm SECTION	1	
12	FACE SEAL OMNISEAL 400A 133.4mm ID x 3.1mm SECTION	1	
13	GREASE HIGH TEMPERATURE	2g	

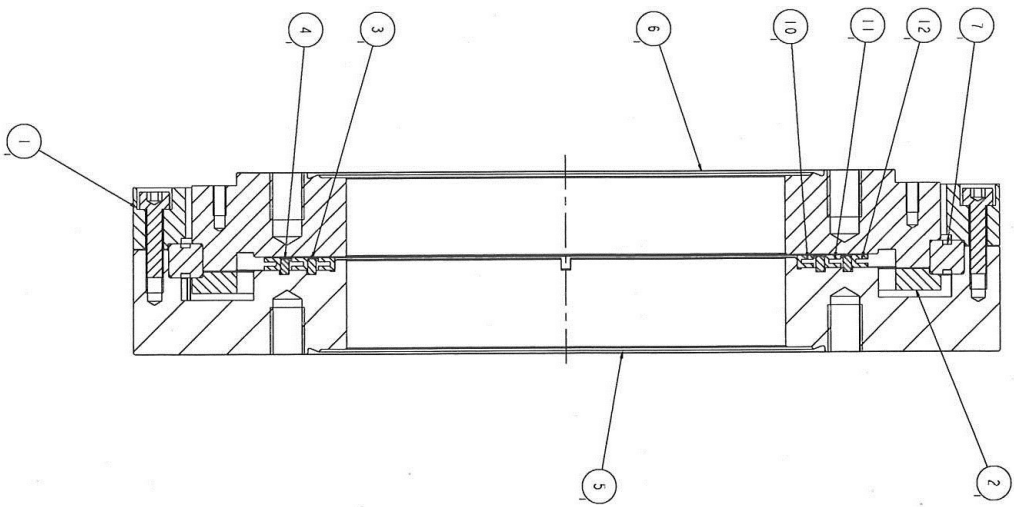

ITEM	DESCRIPTION	QTY
1	VERNIER MOUNTING BLOCK	1
2	VERNIER INDICATOR	1
3	INDICATOR DIAL	1
4	BUSH	2
5	MAIN BEARING ASSY RP100	1
6	SCREW, CSK M3 X 16	8
7	SCREW CAP HD M6X35 LG -	2
8	SCREW, PAN HD M3 X 8L	2
9	STAINLESS STEEL M3 WASHER T0D X 3.31D X 0.5THK	2
10	PIN SPANNER (NOT SHOWN)	1

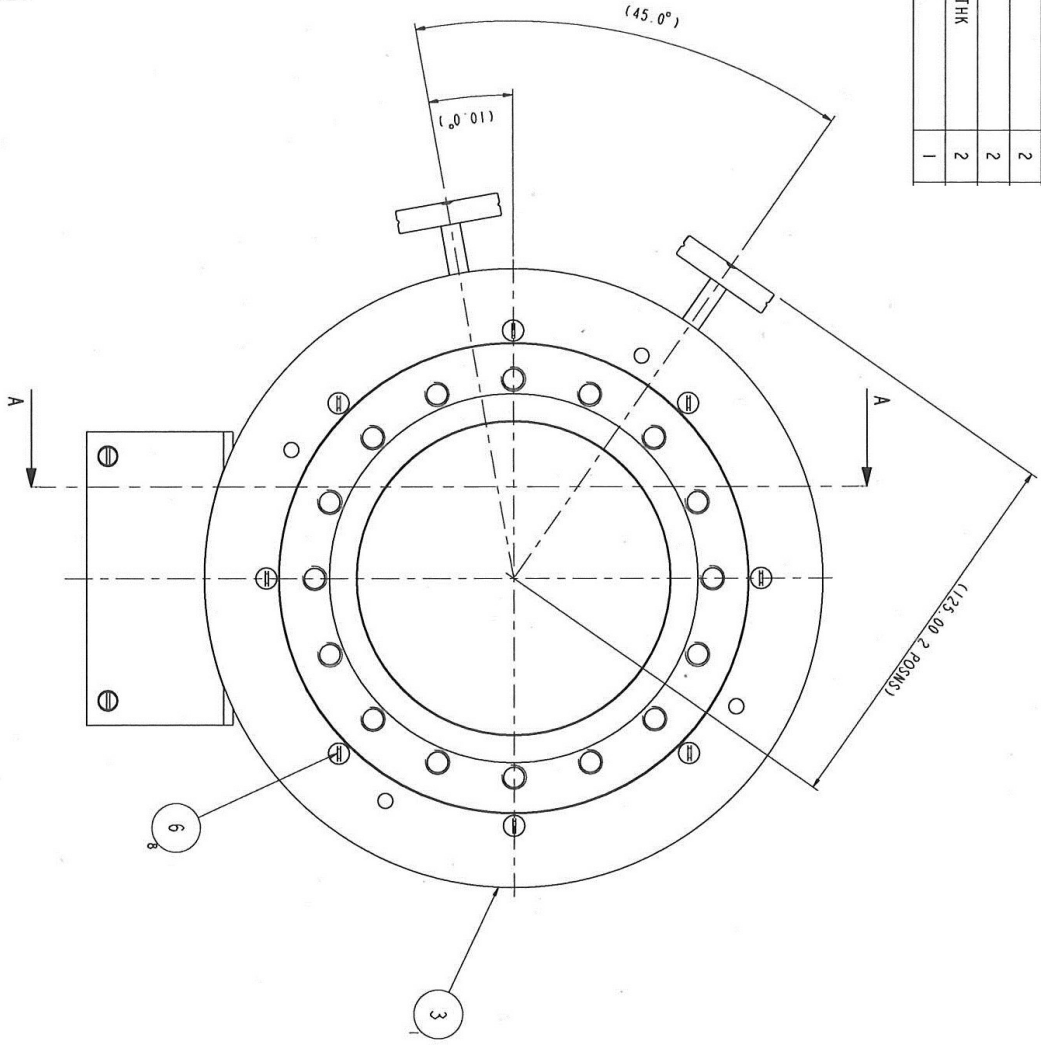
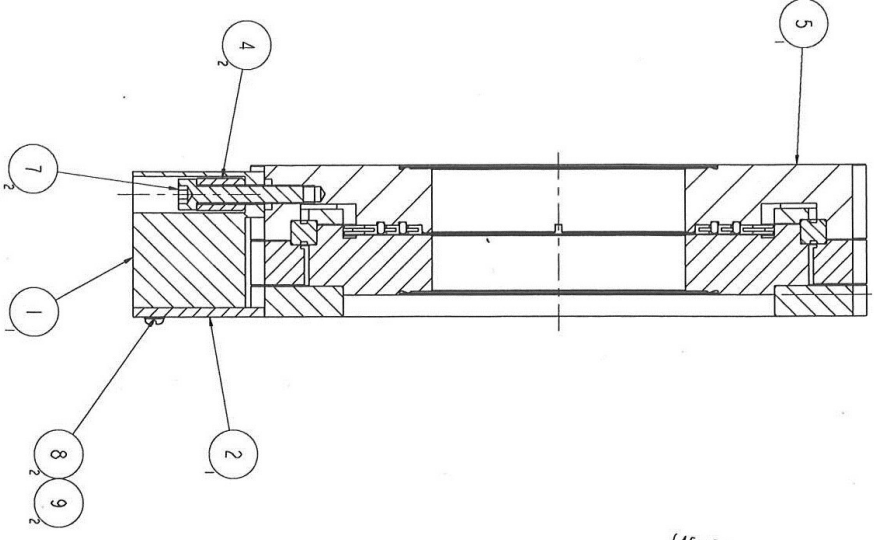

SECTION A-A

ITEM	DESCRIPTION	QTY
1	VERNIER INDICATOR	1
2	INDICATOR DIAL	1
3	BUSH	2
4	WORM HOUSING	1
5	WORM GEAR	1
6	WORM WHEEL	1
7	BEARING PRELOAD NUT	1
8	MAIN BEARING ASSY RP100	1
9	BEARING, RADIAL 22 OD x 8 ID x 7 THK LUB 05:1A	2
10	HANDWHEEL ASSEMBLY	1
11	SCREW, CSK M3 X 16	8
12	M3 CAP HEAD SCREW 12 LONG	8
13	SCREW CAP HD M6x35 LG -	2
14	SCREW, PAN HD M3 x 8L	2
15	STAINLESS STEEL M3 WASHER 7OD x 3.3ID x 0.5THK	2
16	STAINLESS STEEL M6 WASHER 10.5OD x 6.5ID x 1THK	2
17	WASHER SPECIAL ST:STL 12 OD x 8.05 ID x 0.61 THK	1
18	BEARING PRELOAD WASHER	1
19	RP100 SHIM	1

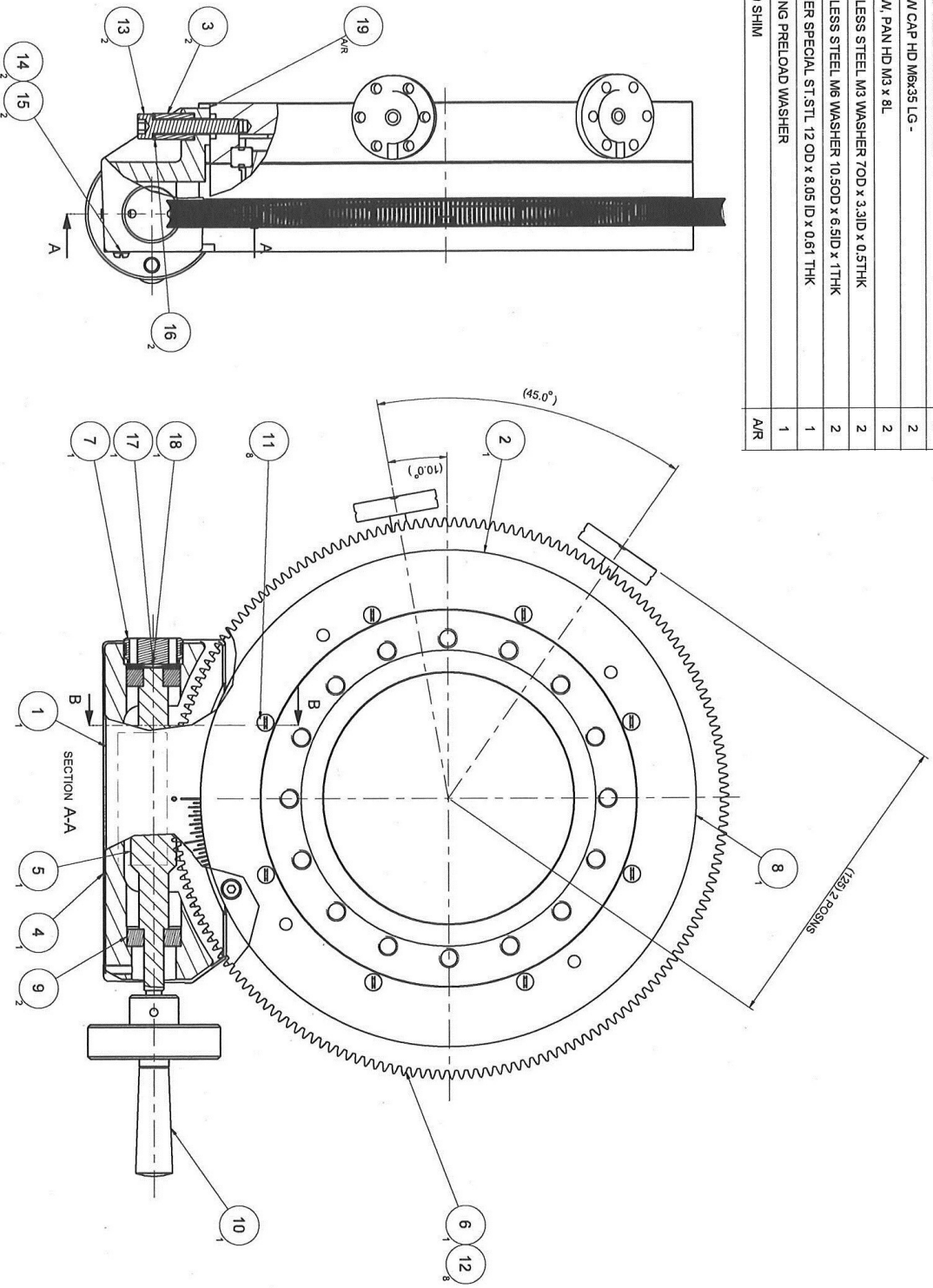

SECTION B-B

SECTION A-A