

Operating and Maintenance Handbook

OMNIAX TRANSLATOR SERIES



REVISION	DATE	COMMENTS	INITIALS
A	Jan 1994	Original release	MJD
C	Sept 1997		ECN2765
D	Aug 2015	VACGEN rebrand	AJL

Copyright Notice 2002 by VACGEN. All rights reserved. Information contained in this handbook is subject to change without notice and does not represent a commitment on the part of VACGEN. No part of this document may be copied or distributed, transmitted, transcribed, stored in a retrieval system or translated into any human or computer language, in any form or by any means, electronic, mechanical, magnetic, optical, manual or otherwise or disclosed to third parties without the express written permission of VACGEN, Maunsell Road, Castleham Industrial Estate, St, Leonards on Sea, East Sussex, TN38 9NN, UK

WARRANTY

1. Subject to fair wear and tear and the due, observance of any installation user, storage, operating or maintenance instructions the Seller undertakes to replace or, at its option repair free of charge to the purchaser, any goods which the purchaser can establish are defective by reason of defective workmanship or materials which are returned to the Seller, carriage paid, within 12 months of the date of dispatch by the Seller. In the event, however, that the Seller supplies spare parts either direct, or that are fitted or installed or replaced by the Sellers' service center such spare parts will be subject to a warranty period of six months only.
2. The Purchaser cannot return any product for warranty repair without the prior approval of VACGEN and the issue of a Goods Return Number (GRN). This shall be obtained by contacting the service center at VACGEN. All returned products must be accompanied by a completed Declaration of Contamination form. Customers must, in the first instance, contact the local selling agent.
3. We reserve the right to decline to service equipment, we consider is in any way hazardous until a clearance or safety certificate, in a form satisfactory to VACGEN, has been completed and returned by the customer.

REPAIR

The following additional terms and conditions apply in the event that the customer elects to use the services of VACGEN workshop on a chargeable basis.

1. At its own cost the customer shall dispatch the equipment to the workshop, carriage paid, suitably packaged, protected and insured, bearing, a Goods Return Number (GRN) and a completed Declaration of Contamination certificate obtained from VACGEN in advance of shipment.
2. During the period that the equipment is on VACGEN premises, VACGEN will insure the equipment against all risks.
3. Vacuum Generator will provide an acknowledgement of the receipt together with an estimate of the repair charges. Such estimates are carried out on a visual basis and are therefore intended as a guide only. Formal fixed price repair quotations are available and involve the disassembly of the equipment to determine the full extent of the work necessary to restore the equipment to an acceptable standard. In the event that the customer chooses not to proceed with the repair VACGEN will make a charge to cover this examination effort.

Note:

The above are extracts from VACGEN Conditions of sale. Complete copies can be obtained from: VACGEN, Maunsell Road, Castleham Industrial Estate St. Leonards on Sea, East Sussex, TN38 9NN, United Kingdom.

1. INTRODUCTION

1.1 HEALTH AND SAFETY INFORMATION

This equipment is a component for use with vacuum systems. Whilst every effort has been made to eliminate hazards, its safe use is also dependant on the system to which it will be connected.

The owner of the equipment must ensure that all users are aware of the Health and Safety information contained in this handbook. If the equipment is sold or passed to another owner, this handbook must be included with the equipment.. If in doubt contact VACGEN.

Warning: This equipment must be installed by qualified personnel.

Warning: It is the responsibility of the user to consider the safety requirements of hazardous materials used with this equipment and the consequence of any leakage, however caused. Consider possible reactions with materials of construction. Any equipment returned to VACGEN must have the correct Declaration of Contamination securely fastened to the outside of the packaging.

Warning: Harmful gases may be evolved if this equipment is heated to temperatures above the maximum specified bakeout temperature.

Warning: Lubricants used in this assembly may cause irritation to sensitive skin. Wear protective clothing.

Warning: Where cryogenic liquids are used with the equipment, it is the responsibility of the user to ensure that the correct safety precautions are taken when handling and storing these materials.

Warning: Safe disposal of the equipment is the responsibility of the user.

Warning: It is the responsibility of the user to fit emergency stops to automated equipment.

Warning: Keep clear of moving pans.

Warning: Do not use this equipment with positive internal pressure above the specified maximum.

Warning: Some equipment may develop extreme hot or cold surfaces. Wear protective clothing.

Warning: Equipment must be fully earthed to prevent dangerous electrostatic charge build-up.

1.2 GENERAL

The OMNIAX is a high precision, high rigidity, UHV specimen translator of modular construction, suitable for a range of X, Y and Z motions. The modular construction means that the specification can be upgraded or modified by the addition or replacement of well defined modules.

The OMMAX has been designed for ease of use and most functions should be straightforward. This handbook outlines the general considerations for installation, use and maintenance.

Most manipulator configurations utilising the OMNIAX translator will also use drives and instrumentation that are not included in this handbook. This handbook should therefore be read in conjunction with documentation supplied for the other equipment.

1.3 SPECIFICATIONS

Support tubes:

Omniax translators can be supplied with either 50mm bore (54mm OD) or 29 mm bore (32mm OD) options.

Positional control:

X, Y: Micrometer or stepper motor

Z: Handwheel or stepper motor

Pressure range:

1 bar to 10^{-11} mbar

Operating temperature:

-20°C to +55°C

Baking temperature:

230°C (motors, instrument cables and other non-bakeable ancillary hardware removed.)

Standard base flange:

NW100CF (151.5mm (6") OD) or NW150CF (202.5mm (8") OD).

Traveling flange:

NW63CF (114mm (4.5") OD)

Environment:

This equipment is intended for use in clean, dry environments. For use in other conditions, please contact VACGEN Technical Sales.

Materials of Construction:

All units are manufactured mainly from austenitic stainless steel or aluminum alloy. Stainless steel is used for parts that form the vacuum envelope. Demountable vacuum seals use copper gaskets. Bearings surfaces may include martensitic stainless steel, bronze alloys and PTFE polymer compounds. Atmosphere side bearing surfaces are normally lubricated with high temperature 'Carbaflo' grease or fluid. The micrometers are conditioned for bakeout to 230°C. Motors contain non-bakeable plastic and must be removed for bakeout. Atmosphere side fixing screw threads are treated with ZTL thread lubricant.

1.4 BASIC DIMENSIONS

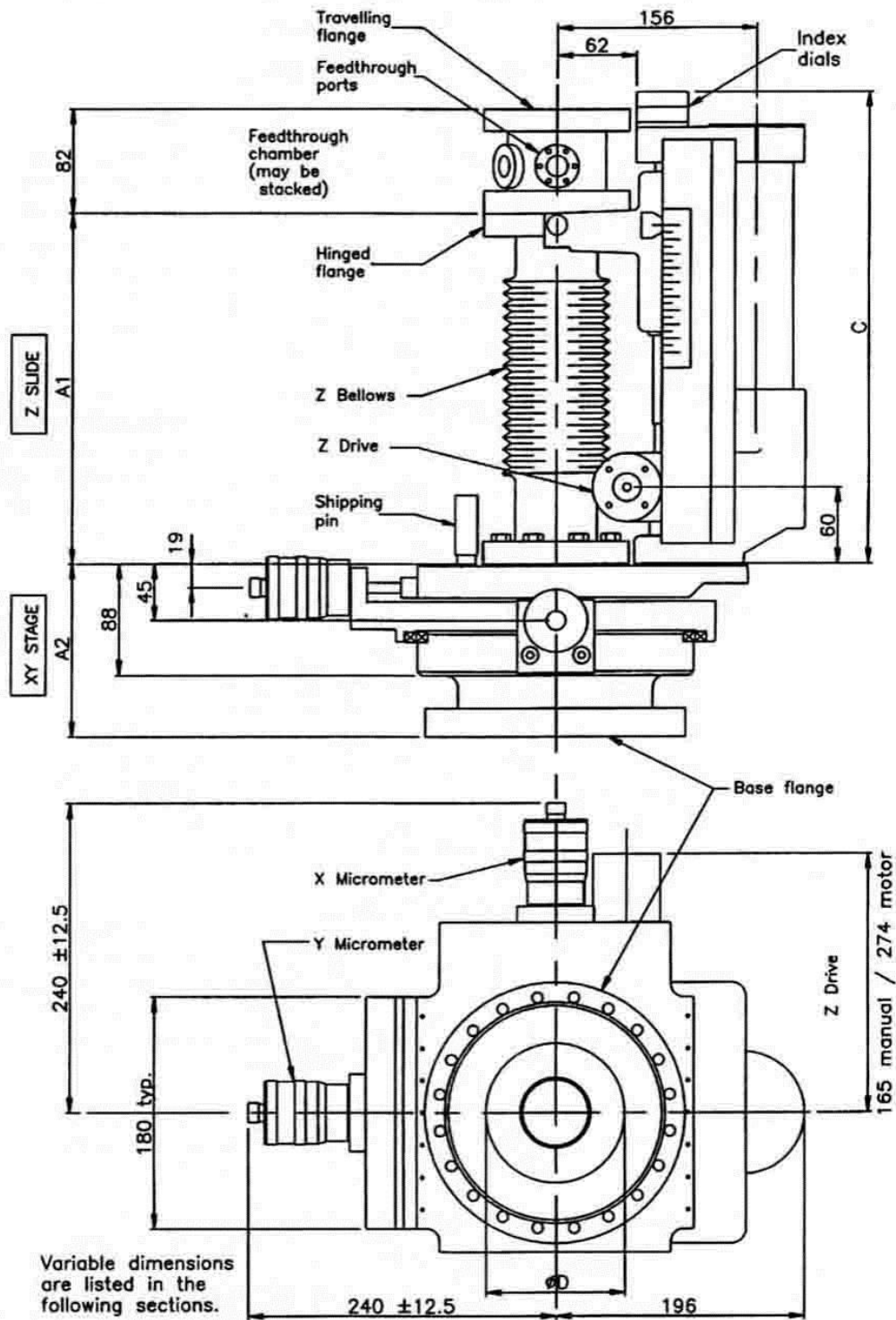

Figure 1 - Basic dimensions and layout of Omniax

1.5 Z MOTION

Z Travel	A1	C	Weight ⁽¹⁾ (kg)
100	184 to 284	374	40
200	186 to 386	477	42
400	186 to 586	677	46
600	229 to 829	920	52

Notes

(1) The weight of the Omniax manipulator will vary depending on configuration details.

(2) Motor specifications assume the

800	273 to 1073	1164	56
1000	317 to 1317	1408	61

Z-SLIDE SPECIFICATIONS:

Resolution	10 microns manual 0.5 microns motorised ⁽²⁾
Repeatability ⁽³⁾	10 microns manual ⁽³⁾ 1 micron motorised ⁽²⁾⁽³⁾
Maximum Speed	4mm/s motorised ⁽²⁾

1.6 XY MOTION

XY Travel	Basic code of XY stage		A2	Bellows bore OD	
	Code	Value		Code	Value
±0	T000	80		95	
±12.5 ⁽⁵⁾	T108	135		85	
±25.0 ⁽⁴⁾⁽⁵⁾	T208 ⁽⁴⁾	167		85 ⁽⁴⁾	
±25.0 ⁽¹⁾	T211	175		108	

XY STAGE SPECIFICATIONS:

Resolution	5 microns manual 0.5 microns motorised ⁽²⁾
Repeatability ⁽³⁾	5 microns manual ⁽³⁾ 1 micron motorised ⁽²⁾⁽³⁾
Maximum Speed	4mm/s motorised ⁽²⁾

Caution: these limits are not protected by limit stops or switches

Examples of vectorial sums

For ±1 2.5mm; (X^2+Y^2)=12.5	Xmax =	12.5	10		8.8	5	3
	Ymax =	0	7.5	8.8		11.4	12.1
For ±25mm; (X^2+Y^2)=25.0	Xmax =	25	20	17.6	12		3
	Ymax =	0	15	17.6		21.9	24.8 1

2. INSTALLATION

2.1 IMPORTANT - READ BEFORE UNPACKING

Warning: Take care when lifting the unit that the weight and position do not exceed comfortable limits. When installing the device make sure that it is adequately supported at all times.

Warning: Do not operate any of the controls until the XY shipping pin and all transit items have been removed. Failure to do so may result in serious damage to both the translator and vacuum system.

a. With two or more persons, lift out the translator using the lifting handles. DO NOT use bellows, drives or instrumentation as lifting points. Take care not to hit or damage any protruding parts of the translator. Lie the translator on its back or stand vertically on the attached frame.

- b. Carefully inspect the translator for visual signs of damage. The packaging is designed to with stand shock and vibration but some of the fixing screws may become loose, more especially with air freight shipment. All parts should be secure and there should be no 'play' in any of the movements. All screws should be securely fastened but not excessively tight.
- c. Any damage in transit should be, reported to the carrier and to VACGEN at Hastings, or your local agent, within three days. Retain the packaging.
- d. Remove the shipping pin and all transit items before operating any of the controls.

2.2 INSTALLATION GUIDELINES

Warning: This equipment must be installed by qualified personnel.

Warning: It is the responsibility of the user to consider the safety requirements of hazardous materials used with this equipment and the consequence of any leakage, however caused. Consider possible reactions with materials of construction. Any equipment returned to VACGEN must have the correct Declaration of Contamination securely Fastened to the outside of the packaging.

Warning: Lubricants used in this assembly may cause irritation to sensitive skin. Wear protective clothing.

Warning: It is the responsibility of the user to fit emergency stops to automated equipment.

Warning: Equipment must be fully earthed to prevent dangerous electrostatic charge buildup.

- a. The OMNIAX will operate when mounted in any orientation. However, because of the weight of the translator, very careful consideration must be given to ensuring that the level of stress exerted onto the chamber and within the translator itself is as low as possible. Where practical the translator should be vertically mounted. For horizontally mounted units, special mounting arrangements are required. See Appendix A.
- b. It is not possible to generalize on mounting arrangements for other orientations. Any supporting cradle must allow for X & Y motions as well as supporting the weight of the frame. Also the centre of gravity will vary as the Z motion is used. Normally this is not significant but must be considered where very long Z travels (800mm and greater) are used or where heavy equipment is being moved on the Z slide.
- c. Bolt to the system flange using the correct size bolts and gaskets as indicated in the table below. For tapped flanges use a thread lubricant, such as VACGEN ZTL on the bolt threads. Use washers under bolt heads or nuts.

Flange details

Flange Size:	NW63CF (4.5" OD)	NW100CF (6" OD)	NW150CF (8" OD)	NW200CF (10" OD)
Gasket size (VG reel):	ZCU64	ZCU100	ZCU150	ZCU200
Tapped holes:	M8	M8	M8	M8
Clearance holes (mm):	O8.4	O8.4	O8.4	O8.4

- d. Install equipment to the top flange, using the same guidelines as the base flange.
- e. Fit and adjust the micrometers or motors as described in the sections below. When installing use only the lifting handles. These are found at the base and top of all manipulators and should remain attached until the translator is correctly mounted.
- f. Before operation, remove the lifting handles and the shipping pin.

2.3 XY MICROMETER INSTALLATION

Caution: Note the vectorial limits of travel as given in the 'XY Motion' section of the introduction. Exceeding these limits can permanently damage the bellows. There are NO stops fitted to restrict vectorial movement.

a. Some micrometers are supplied with the barrels intentionally loose in the housing. With the shipping pin in position, adjust the micrometers to read the central position of the stage. The graduated thimble can be rotated to 'zero' the scale. Tighten the clamp and remove the shipping pin for use.

Warning: It is the responsibility of the user to fit emergency stops to automated equipment. (Note: VACGEN stepper motor controllers have a facility for adding emergency stops.)

2.4 XY MOTOR INSTALLATION

- a. Motor wiring details are given in Appendix B.
- b. Bolt the stainless steel block and lead screw assembly to the slide.
- c. Screw the anti-backlash assembly onto the lead screw.
- d. Carefully fit the main mounting block over this assembly. Secure the anti-backlash assembly by tightening the single lead screw, located under the plate, against the central spacer. It may be necessary to unscrew the anti-backlash assembly to achieve this.
- e. Rotate the anti-backlash assembly so that the mounting block is within 1mm of the side of the XY Table. (Tip: The pulley can be turned around and used as a convenient handwheel.)
- f. Remove the shipping pin and loosen the stainless steel block holding the lead screw.
- g. Bolt the mounting block to the side of the Table using 3 x M6 bolts.

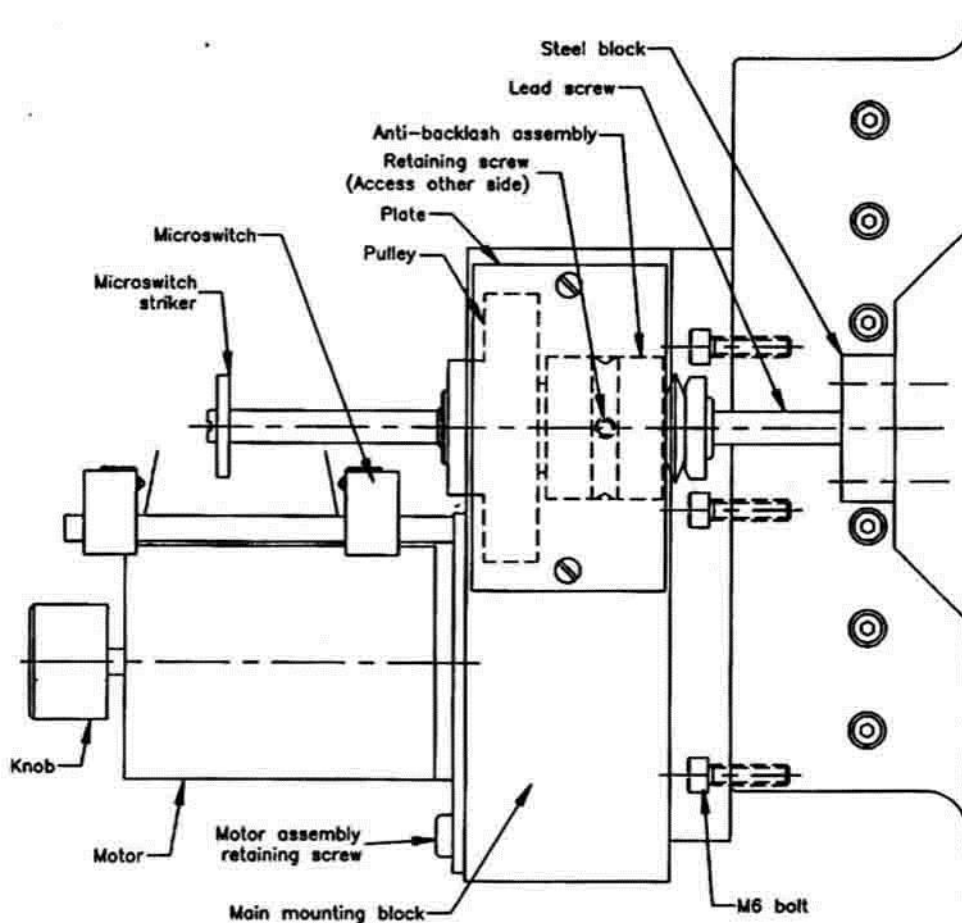

Figure 2 - Motor on T108, T208 and T211 tables

2.5 XY MOTOR LIMIT SWITCHES

- Remove the shipping pin and switch off any power to the motors.
- Use the manual knob to move either motor from the central position to either limit of travel.
- Loosen the limit protection microswitch and adjust its position until the switch can be heard to operate (click) at the limit position. Repeat for the other limit of travel.
- Return the first motor to the central position before attempting to set the second pair of microswitches.

Caution: Microswitches do not protect against vectorial limits unless they are set to the 45° vector, i.e. $X=Y=5.5\text{mm}$ for $\pm 612.5\text{mm}$ stages, or $X=Y=17.6\text{mm}$ for ± 25.0 stages. It is important that both microswitches are correctly adjusted so that there is no risk of driving into the end stops as this may damage the support tube, XY bellows or drive mechanism.

Caution: Microswitches are intended for emergency use only. Do not use microswitches as position indicators or datum markers. Stepper motors may overrun by several steps when a microswitch is activated, particularly if traveling at speed. Always check the datum position and reset as necessary.

2.6 Z MOTOR INSTALLATION

Note: Changing the side to which the motor is fitted is possible, but will cause the direction of motion to reverse. It is therefore necessary to reverse the microswitches.

- a. The motor is assembled with a housing and the sprung part of an Oldham coupling. This assembly is fitted over the locator which is permanently mounted to the Z slide of the Omniac.
- b. As the motor is being fitted, rotate the motor shaft by hand to engage the coupling. Once positioned, tightened the thumbscrew into the groove on the locator to secure the motor.

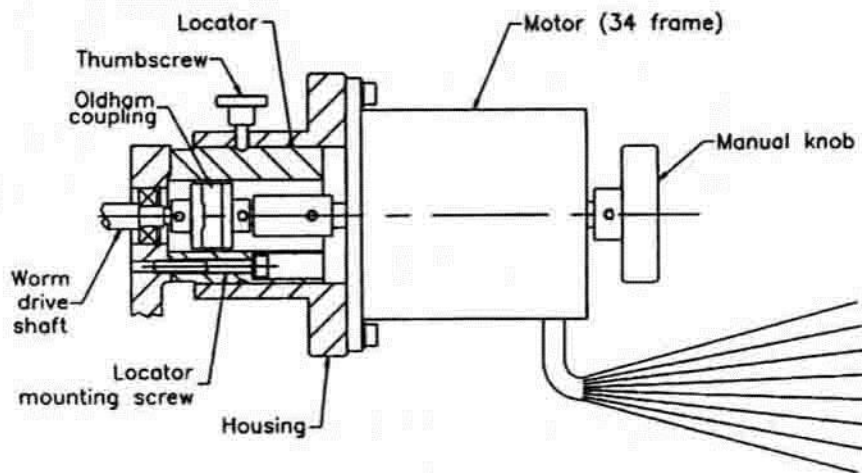

Figure 3 - Z Motor arrangements

2.7 Z MOTOR LIMIT SWITCHES

Caution: It is important that both microswitches are correctly adjusted so that there is no risk of driving the knee into the end stops as this may damage the drive mechanism or lead screw.

Caution: Microswitches are intended for emergency use only. Do not use microswitches as position indicators or datum markers. Stepper motors may overrun by several steps when a microswitch is activated, particularly if traveling at speed. Always check the datum position and reset as necessary.

The microswitches are located inside the cover extrusion and are removed for bakeout with the extrusion. Move the knee away from the switches by at least 25mm before removal or replacement of this cover. The microswitches should be factory set. Check by slowly driving the Z-slide to either end of travel until the switch operates, preventing further movement in that direction. To reset the microswitches;

- a. Position the knee at the limit position required.
- b. Loosen the two screws holding the microswitch mounting bracket to the cover extrusion and slide the bracket to a position where the microswitch makes contact.
- c. Re-tighten the two screws and check, by slowly running the knee onto the switch, that contact is being made consistently.

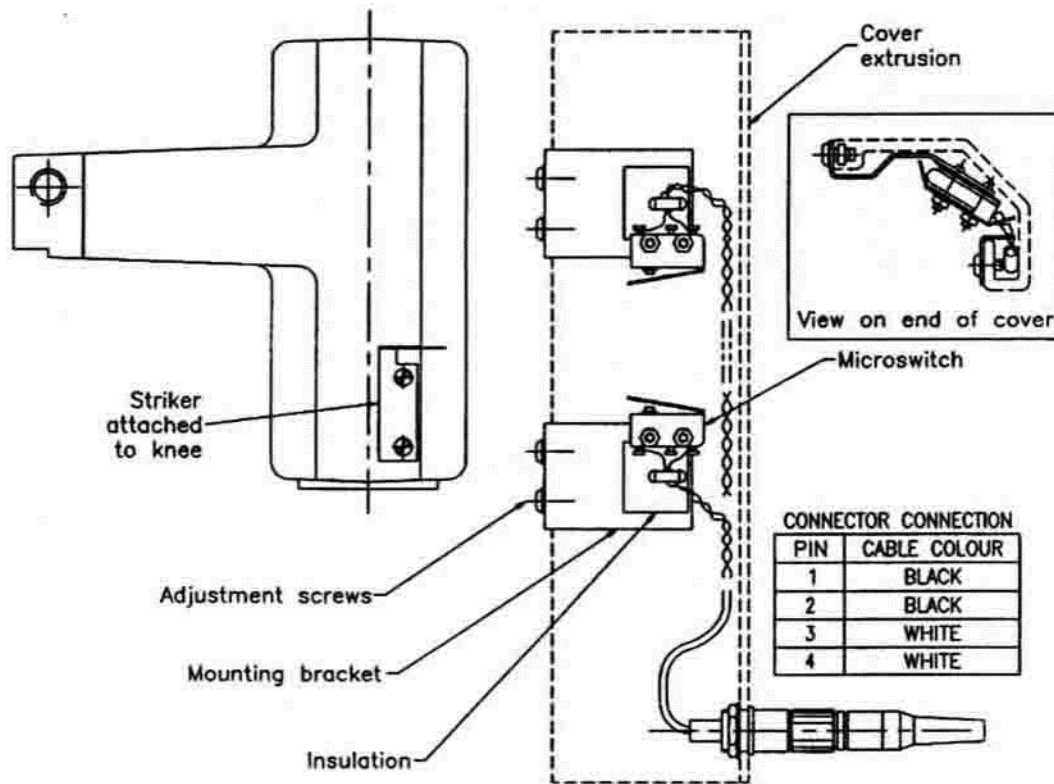

Figure 4 - Z slide Microswitch layout (schematic)

3. OPERATION

3.1 NORMAL USE

3.1.1 Important information

Warning: Do not use this equipment with positive internal pressure above the specified maximum.

Warning: Keep clear of moving parts.

Caution: Do not operate unless the shipping pin is removed (see figure 1).

Caution: The Omniax uses precision guidance mechanisms: avoid undue strain due to clashes with fixed objects, exceeding the vectorial limit, overloading the top flange, leaning on the equipment, etc.

Caution: Where motors are fitted, the motor connector must not be disconnected unless the power to the drive has first been switched off. Allow a few seconds for the circuits to discharge.

Caution: Microswitches are intended for emergency use only. Do not use microswitches as position indicators or datum markers. Stepper motors may overrun by several steps when a microswitch is activated, particularly if traveling at speed. Always check the datum position and reset as necessary.

3.1.2 Operation

- The unit must be correctly installed, and the information above followed carefully.
- Manual operation is straightforward and needs no special consideration.

- Operation with the stepper motor is dependant on the motor controller used, and the user should refer to the controller instructions.
- If any movement becomes tight, or if backlash (play) becomes visible, the unit will require maintenance.
- Routine maintenance is required. See section 4.1

3.2 BAKEOUT

3.2.1 Bakeout guidelines

Warning: Harmful gases may be evolved if this product is heated above the maximum specified bakeout temperature.

- Heater tape should not be used over the bellows and should be avoided on all manipulation equipment as it can cause local hot spots.
- The temperature sensing element controlling the heaters must be suspended in air near the translator and at a level approximately 50 -100 mm below the highest part of the translator.
- In no event should the temperature sensing element be in contact with or attached to any part of the translator or the vacuum system, i.e. it must always sense the air temperature.
- Centralize the XY stage and, on horizontally mounted translators, position the Z slide at mid-travel.
- Remove all microswitches and motors as described below..
- Remove all non-bakeable equipment from the bakeout zone.

3.2.2 Removing motors for bakeout

- a. Switch off the controller before disconnecting any motor.
- b. For the XY motors, remove the three screws securing the motor mounting plate and remove the motor, microswitches, drive belt and all cabling from the bakeout zone.
- c. For the Z motor, first move the knee away from the limit positions by a minimum of 25mm. Unplug the connector between the motor and microswitch cover. Loosen the single thumb screw on the motor housing and remove the motor. Remove the cover extrusion that encloses the microswitches by unscrewing the two screws securing it to the side of the Z-slide. Remove all cabling from the bakeout zone.

4. MAINTENANCE

4.1 ROUTINE MAINTENANCE

4.1.1 Inspection schedule

The following inspections and procedures should be performed after 150 to 200 hours of accumulated bakeout or when the Z-slide has traveled 150m.

4.1.2 Screw fixings

Check that all screws are secure: not slack nor excessively tight. It will be noted during any dismantling that Belville washers (disc springs) have been fitted under certain screw heads. It is important that these washers are refitted in the correct locations.

4.1.3 Gravity compensation springs

(Horizontally mounted units only):

Warning: The spring compensators are pre loaded and have sharp edges do not attempt to dismantle.

- Visually inspect the springs to check that no spring leaves have broken. Any broken springs must be replaced as soon as possible. Contact VACGEN Service Department for information.
- Check that the springs correctly support the payload by operating the vertical (Y) micrometer (or manually operate the Y motor). It will be possible to find a position where the resistance to raising the stage is the same as the resistance to lowering it. This is the neutral position.
- Check that the neutral position is within 5mm of the central position. If the neutral position is beyond this limit, the compensator is not balanced, and action is required to correct it. Contact VACGEN Service Department for information.

4.1.4 XY Micrometer or motor stiffness

- Compare the action of the X and Y drives by hand operation at the neutral position (see above to establish the neutral position). Both movements should feel smooth and have the same degree of stiffness. If a movement is believed to be stiffer than normal, proceed as follows:
- At the neutral position, loosen (but do not remove) the screw(s) that secure the micrometer or motor housing to the XY table. Repeat the check for stiffness.
- If the drive is now significantly smoother or less stiff than previously, the slides may have loosened or the drive may be misaligned with the XY table.
- Check for loosened slides.
- Check for misalignment by observing the gap between the micrometer (or motor) and the housing when the bolts are just loosened. An uneven gap indicates misalignment. This can be rectified by fitting shims: e.g..
a thin sheet or foil between the housings at the correct position to eliminate misalignment.
- If the drive remains stiff, this may be due to incorrect lubrication, wear of the drive, or damage.

4.1.5 Monitoring the Two-Part Nut on the Z slide

The two-part nut helps prevent collapse of the Z-slide into the chamber in cases of extreme thread wear. The diagram below shows the arrangement.

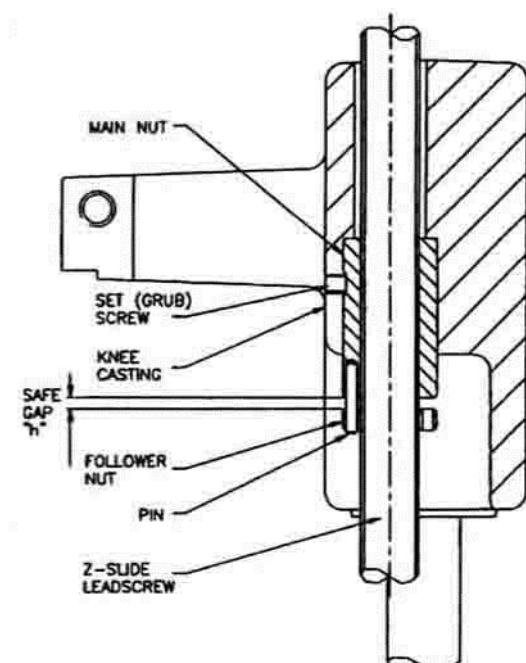

Warning: It is essential for safety reasons that regular checks are made.

- The rate of wear depends on many factors such as lubrication, usage, applied load and orientation.
- When failure of the main nut occurs the gap between the two nuts (shown as 'h' in the figure) will become zero as the full load is taken on the follower nut. **Warning:** The slide must not be used in this condition; if usage continues, a dangerous collapse is possible.
- The condition of the nut must be monitored to ensure that wear of the main nut is never such that the follower nut is needed to support the load.
- The state of wear of the main nut can be checked by monitoring the following three conditions:

- a. The gap distance, h: If the gap reduces by 0.5mm from that measured when first installed, the nut should be replaced.
- b. The torque required to turn the worm gear shaft: If the torque required reaches a level of 40Ncm (60 oz.in), the nut should be replaced.
- c. The free play of the follower nut on the pin connecting it to the main nut: If the follower nut has no free play on the pin, the nut should be replaced.

4.1.6 Lubrication

Warning: Lubricants used in this product may cause irritation to sensitive skin. Wear protective clothing.

Note that Carbaflo grease discolours with time, particularly where regular bakeouts are applied to the equipment. This is normal and does not affect the behavior of the lubricant.

a. Z slide lead screw, linear guide shafts, worm and wheel gears:

Clean dirty and excess grease off the components. Lubricate with Carbaflo grease, ensuring that all contact surfaces are covered by a film of grease. Should the slide develop a dry squeak, lubricate immediately.

Warning: *Keep clear of moving parts.*

b. Z slide ball bearings (drive screw and worm drive shaft):

Use a small quantity of Carbaflo fluid to lubricate each bearing. Apply using a dropper or by dipping a clean wire into the container and allowing it to drip onto each bearing.

c. Z slide Oldham coupling (motorised Z slide only):

Clean dirty and excess grease off the coupling. Lubricate with Carbaflo grease.

d. XY Micrometers:

Move one micrometer at a time to the limit position so that the spindle is fully retracted. Unscrew and remove the small knurled knob that retains the micrometer thimble. Pull the thimble away carefully. Apply Carbaflo grease to the lead screw. Replace the thimble and knob.

e. XY stage motor lead screw:

Drive the motor to either limit of travel, periodically stopping to lubricate the lead screw as it becomes visible on either side of the anti-backlash assembly.

Warning: *Keep clear of moving parts.*

f. XY Slides:

Use a small quantity of Carbaflo fluid to lubricate the slide. Apply using a dropper or by dipping a wire into the container and allowing it to drip onto the exposed slide. Note that it is not possible to lubricate the full length of the slide, but by cycling the movement a few times, the lubricant will be adequately dispersed.

g. Fixing screws:

All fixing screws should be treated with high temperature thread lubricant.

4.1.7 Adjustment of the XY slides

- a. If play develops in the XY slides, three adjustment screws are provided on each axis. The X slide adjustment screws are located below the Y axis micrometer (or motor). The Y adjustment screws are on the side of the top plate, on the same side as the shipping pin.

- b. Before adjusting these three screws, it is first necessary to loosen the screws which retain the bearing closest to the adjustment screws.
- c. Check that the roller cage between the slides is centrally positioned along the length of the slide.
- d. Tighten the middle adjustment screw first, to finger tight only. Then tighten the outer adjustment screws, to finger tight.
- e. Finally, tighten the bearing retaining screws.

4.2 CORRECTIVE MAINTENANCE

4.2.1 Guidelines for dismantling and re-assembly

- a. Centralize the XY stage and retract the Z slide, but leave the knee at least 25mm away from the limit positions.
- b. Disconnect all power and instrumentation and remove the OMNIAX from the vacuum chamber.
- c. Bolt the Omniax to a suitable stand that allows it to be worked on securely in the vertical position (such as the transit stand supplied with the translator).
- d. Note the orientation of parts as they are dismantled: i.e., disk (or Bellville) spring washers under screw heads, the orientation of bearings and tubes.
- e. When reassembling always fit new copper gaskets.
- f. Apply thread lubricant to all fixings which are not in-vacuum but do not allow contamination of the vacuum with thread lubricant.
- g. Replace parts in their original orientation.

4.2.2 Removal of the central assembly

(i.e.: support tube + sample holder + Z bellows + rotary drive or other equipment fitted above the knee).

- a. All sample handling equipment must either be removed from the bottom of the manipulator, or be able to pass through the support tube bearing: i.e., through a bore equivalent to the outer diameter of the support tube. It will be necessary to remove the radial screws which retain the rotary drive bearing housing.
- b. Remove the Z drive hand wheel or motor. Loosen the grub screw holding the knurled nut on the Z drive worm shaft (see diagram below). Unscrew this nut by about two turns relative to the spacer which has a radial hole. This will introduce end play to the shaft

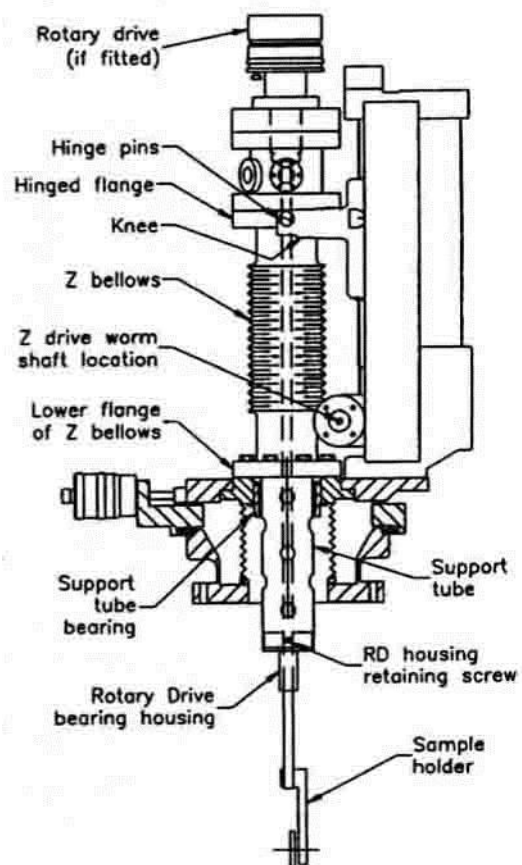

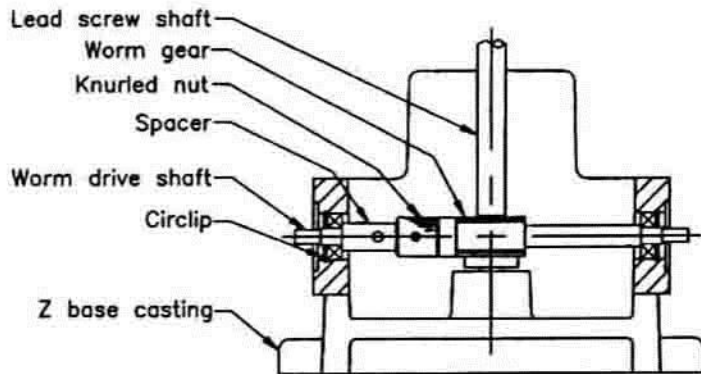

- assembly. Remove the circlip from the side shown in the diagram and remove the shaft.
- c. Unscrew and remove the eight 13 mm AIF nuts which hold the lower flange of the Z bellows to the XY module.
 - d. Unscrew and remove the two hinge pins which retain the upper bellows flange to the knee. Carefully lift the assembly away.

Note: some Omniax translators (normally long travel versions fitted with the 32mm diameter support tube) have a hidden pin that prevents the top flange rotating. In this case, pull the top flange away from the knee before lifting the assembly away. It may be necessary to prise the knee forward by carefully using a screwdriver as a lever tool.

- e. Replacement is a reversal of the above procedure but note that the end play must be taken out of the Z drive worm gear shaft by tightening the knurled nut against the circlip (it will help to press firmly against either end of the shaft to seat the circlip).

4.2.3 Z-slide removal

- a. First remove the central assembly.
- b. Unscrew and remove the eight M6 bolts that secure the Z slide casting to the top plate of the XY stage, and assembly away.

4.2.4 Z bellows removal

- a. First remove the central assembly.
- b. Remove the sample handling equipment from the the manipulator, including all instrumentation services. vary depending on the configuration. The following text VACGEN rotary drive is used.
- c. Check the condition of the rotary drive shaft that from the bearing housing. Carefully clean off any burrs or high spots that prevent the shaft from being drawn through the bearing housing. surface of the protruding rotary drive shaft with alcohol withdraw the rotary drive. Be careful to avoid straining drive shaft which is now unsupported.
- d. Remove the eight MS cap head bolts holding the chamber or other such device to the hinged flange.
- c. Looking inside the hinged flange, loosen the M4 that are exposed (but do not remove).
- f. Remove the spiral retaining ring by prising out at the start point and working out of the groove and remove the support tube through the hinged flange.
- g. All bellows are fragile and expensive to replace. Please handle with care.

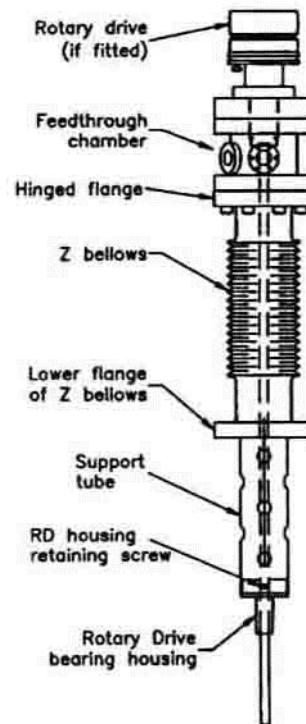

CENTRAL ASSEMBLY

the base of lift this bottom of Details will assume a protrudes might Wet the and the rotary feedthrough grub screws

h. When refitting the support tube to the hinged flange, tightening the grub screws around the flange by a small amount in turn to avoid jamming.

4.2.5 XY bellows removal

- First remove the central assembly and Z-slide.
 - Note carefully the orientation of the support tube bearing: a single small hole identifies the fixed side of the bearing (see diagram below). Remove the four M4 screws which retain the bearing and remove the bearing assembly from the XY stage.
 - Remove the six M6 hexagon head bolts around the top flange of the XY stage. Note that these are not equispaced.
 - Remove the ring of twelve M6 hexagon head bolts that hold the flared tube to the underside of the XY table. The XY bellows can now be removed.
- c. All bellows are fragile and expensive to replace. Please handle with care.

4.2.6 Support tube bearing removal

- Refer to XY bellows removal above, but when reinstalling, ensure that bearing is orientated correctly: Horizontally mounted translators must have the fixed side of the bearing down most. Vertically mounted units which are subject to transfer forces should have the fixed side opposite to the main transfer device.

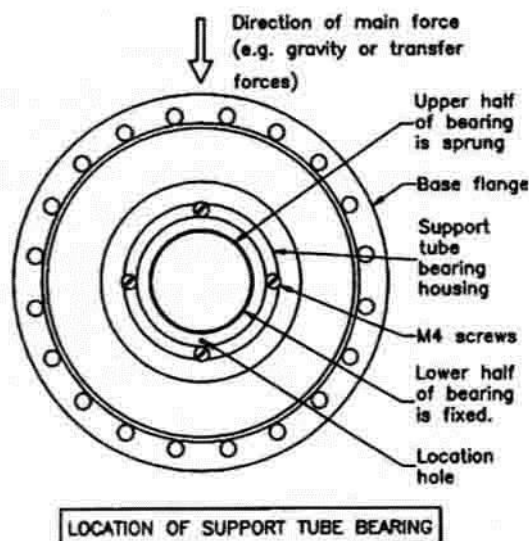

4.2.7 Spares and Accessories

Lubrication kit LUBEK, including; VG Thread Lubricant, Carbaflo grease, solvent for Carbaflo and gloves.

Tool kit TOOLK, including; Metric spanners, hexagon keys, circlip pliers and gloves

Electrical and VACGENcouple instrumentation: EFT series feedthroughs:

Contact VACGEN for available feedthroughs and for information on instrumentation options.

Rotary Drives: RD series (RD I, RD2 and RD224) precision rotary drives. These are compatible with the Omniax.

Sample Holders and Sample Mounts: SH series: An extensive range of compact sample handling options is available, many in low magnetic materials as standard. These include secondary rotation sample mounts (or sample holders); Sample heaters for resistive or electron beam heating,

HST and EBH series; Sample cooling accessories, LN and LNRX, integrated sample transfer system, the XL25 series, and others. **Sample Accessories:** VACGEN can provide individual items of sample hardware, such as UHV compatible wiring, molybdenum screws, ceramic isolators and so on. Please state your requirements clearly.

Motors: Manual Omniax actuators can be upgraded to stepper motor options. Most rotary actuators can also be upgraded. Incremental encoders versions are also available. Please state your requirements clearly.

Motor controllers: The SDU, SMC and SMC-E series of powerful, bipolar motor controllers can be used to operate any VACGEN motor, or any other 4 phase hybrid stepper motor.

Z-slide nut replacement: MXNUTK. Service kit for replacing the lead screw nut in cases of extreme wear.

Associated Equipment: Details of rotary drives, specimen manipulators, heating, cooling and other accessories are covered by separate instructions. If in any doubt regarding compatibility or fitting procedure, contact VACGEN for assistance

4.2.8 Factory Servicing

A factory servicing scheme exists for all translators. The translator should be returned to the VACGEN factory with a covering order. Please note also the terms and conditions for returning goods, outlined in the 'Repair' section in the front of this manual that apply to good returned for servicing. The servicing scheme includes a complete strip down, cleaning, re-lubrication and re-assembly.

When shipping the unit use the original packing and pack with care to avoid expensive transit damage. Consider that the crate is liable to be dropped on any face or corner.

APPENDIX A. HORIZONTAL MOUNTING

AI. INTRODUCTION

The purpose of correct horizontal mounting compensation is to relieve the Y-axis micrometer of excessive load and to reduce stresses on the chamber and components of the translator. Suitable compensation must be used on all OMMAX units.

Three options are available:

- * Option A is mainly used where the 'Z' travel is 600 mm or less.
- * Option B is required to support units with Z travels greater than 600mm or where heavy equipment is transported on the 'Z' carriage.
- * Option C is used for fixed XY stages (or "Z-only" adaptors), and is not dependent on extent of Z travel.

In all cases the position and setting arrangement instructions must be followed to ensure that the equipment will work satisfactorily over its full life.

A2. OPTION A: STANDARD COMPENSATOR USA

Description

The HSA compensator comprises a floor mounted sprung lever mechanism, a tube clamp attached to the translator and a connecting push-rod. Constant tension springs on one side of the lever provided an upward force on the opposite side.

Since there are two positions of both the spring drums and push rod mount, four multiplying ratios are possible. Also, the number of spring leaves can be varied and so the upward force can be closely matched to the weight of a particular device.

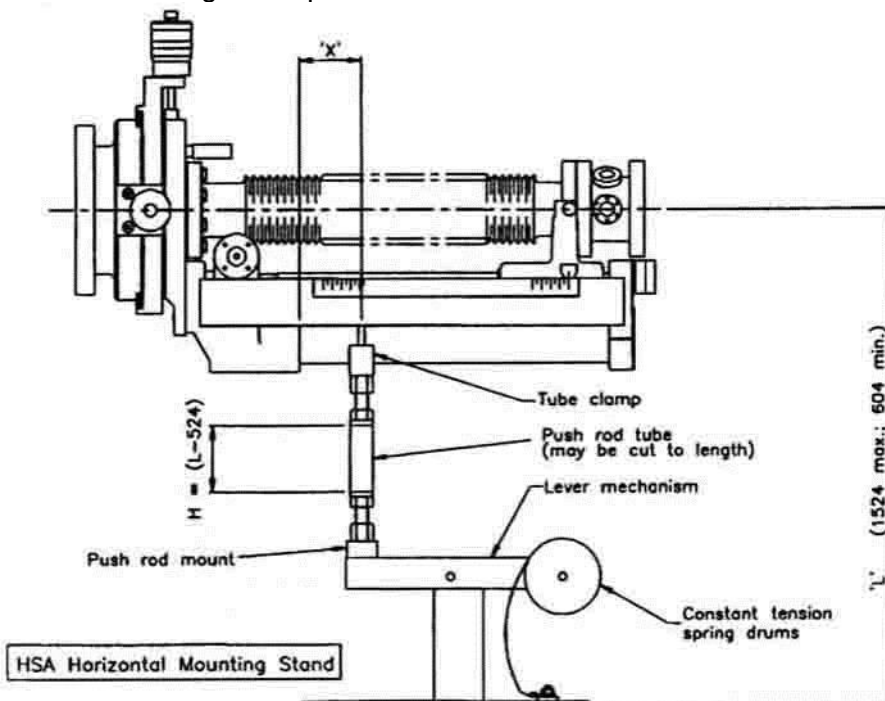

The position at which the compensator acts against the translator can be adjusted by varying the tube clamp position. This should be set at the centre of gravity when the Z-slide is in mid-position.

Spring Parameters

Warning: These springs are very powerful and have sharp edges. GREAT CARE should be taken to avoid physical injury if any attempt is made to disconnect the springs. First remove the translator from

the system. ALWAYS wear tough gloves and remove the spring from the axle rather than the outer end.

These values relate to OMNIAX translators that include XY stage, rotary drive, feedthrough chamber with feedthroughs and normal specimen holders. The Z slide is taken as motorised but the XY stage is manual. For other configurations, such as the CTPO or cryostats, please consult VACGEN.

Z Travel (mm)	Clamp position, X (mm)	Spring Position	Push rod mount position	Total number of spring leaves
100	0		Outer	6
200	0	Inner	Inner	7
300	0	Inner	Inner	7
400	50	Outer	Outer	7
500	90	Outer	Inner	6
600	130	Outer	Outer	8

Important: The system flange will need to carry approximately 25% of the weight of the OMNIAX. Ensure that the system construction is stable is designed to support at least 50% of the full OMNIAX weight. The HSA stand will relieve the majority of the cantilevered weight of the unit.

Normally the OMNIAX will be matched with its compensating stand, and so there will be no need to alter any of the parameters outlined in the table above.

It will be necessary first to ensure that the push rod is of the correct length:

- Establish the correct length, H, of the push rod tube from the measured value, L. ($H = L - 524$). The push rod end fittings should be adjusted to their mid position when making this calculation.
- Pull one of the end fittings from the push rod tube and cut the tube back by the required amount.
- Replace the end fitting.

When ready to install, offer the OMNIAX to the chamber and, **WHILST SUPPORTING THE END CAREFULLY ON JACKS**, bolt to the chamber. Continue to support the device whilst the compensator stand, is maneuvered into position and the push rod is fitted between the two countersunk pivot points. The jacks may now be carefully removed checking the following

* With the X, Y and Z motions at mid travel check that the Y micrometer is as free to move as the X micrometer. If any undue stiffness is noticed or if there is more resistance in one direction than the other, then advice should be sought from VACGEN.

* With the XY stage centralized check that the lever arm is horizontal and the push rod vertical. Adjustment may be made via the end fitting. Also check that full Y travel can be achieved without contact being made with the lever arm stops.

* The base of the stand must be firmly bolted in position.

* **IMPORTANT:** Protect the OMMAX and the compensation unit from accidental knocks that could dislodge the spring loaded push rod and over-stress the system flange.

A3. OPTION B: TRAVELLING COMPENSATOR HSB

Description

This compensation device consists of three separate units using constant tension springs in each case.

* A traveling unit that moves along a track and supports the combined moving weight of the knee, feedthroughs, rotary drive etc.

* An outboard unit at the extreme outer end of the Z slide that reduces the cantilevered moment resulting from the extended mass.

* An XY spring unit that partially supports the static loading by transferring weight onto the chamber flange.

Note that both the traveling unit and the outboard unit utilize a lever mechanism whose principal is explained in the previous section.

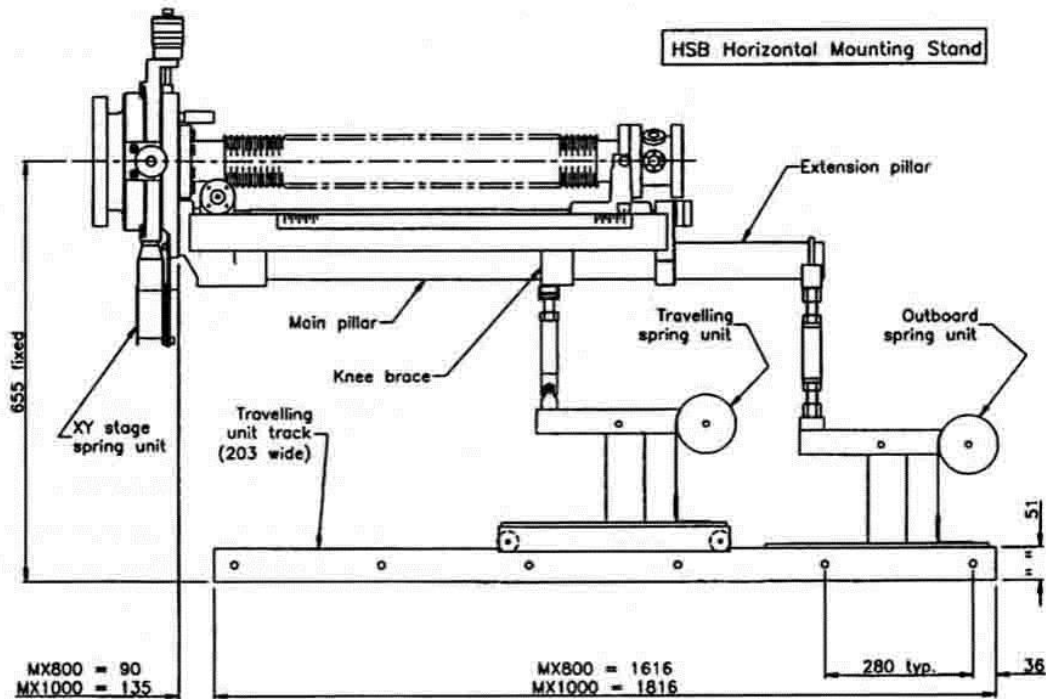

Spring Parameters

Warning: These springs are very powerful and have sharp edges. GREAT CARE should be taken to avoid physical injury if any attempt is made to disconnect the springs. First remove the translator from the system. ALWAYS wear tough gloves and remove the spring from the axle rather than the outer end.

These values relate to OMNIAX translators that include XY stage, rotary drive, feedthrough chamber with feedthroughs and normal specimen holders. The Z slide is taken as motorised but the XY stage is manual. For other configurations please consult VACGEN.

a) Traveling unit:

Z travel (mm)	Spring position	Lower pivot position	Total no. of spring leaves
800	Inner	Inner	4
1000	Inner	Inner	4

b) Outboard spring unit:

Z travel (mm)	Spring position	Lower pivot position	Total no. of spring leaves
800	Inner	Outer	2
1000	Inner	Inner	2

c) XY Spring Unit

The spring drums supporting the XY stage will be fitted with a total of 6 spring leaves. These cannot be adjusted.

Warning: All of the above springs are very powerful and have sharp edges. GREAT CARE should be taken to avoid physical injury if any attempt is made to disconnect the springs. First remove the translator from the system. ALWAYS wear tough gloves and remove the spring drum or spring axle rather than the outer end.

Installation

IMPORTANT: The majority of the OMNIAX weight will be carried by the system flange which must be stable and strong enough to support the full weight of the unit. The HSB stand reduces internal stresses in the OMNIAX and relieves the cantilevered movement applied to the system flange.

Normally the OMNIAX will be matched with its compensator stand and so there will be no need to alter any of the factors outlined in the table above. The track for the travelling unit must be fixed in position as follows:

- a. The level of the track must be parallel with the Z axis of the manipulator (i.e. horizontal) and be the set distances shown from the system mounting flange.
- b. The track should be rigidly bolted in position. If this is not possible, there should be an allowance for the side load on the track which occurs during normal use. This means that the base of any table must be made wider as the track is raised, with the ratio of extra width to extra height of 1:2.
- c. Fit the extension pillar to the top of the Z slide. This is secured by a single screw through the main pillar.
- d. Remove the Z slide extruded covers which carry the scale and switches. Screw the brace into the lowest of three positions possible on the back of the knee.
- e. With the knee brace in position attach the other parts of the traveling spring unit as shown.
- f. Remove the pivot pin to split the assembly into two parts. (This pin will be replaced later).
- g. Offer the OMNIAX to the chamber and, **WHILST SUPPORTING THE ENDS CAREFULLY ON JACKS**, bolt to the chamber. Continue to support the device whilst attaching the traveling compensator by joining the push rod end to the with the pivot pin.
- h. Fit the push rod to the static compensator by the lever and inserting between the two countersunk holes.
- i. The jacks may now be removed carefully checking the following points before applying vacuum:

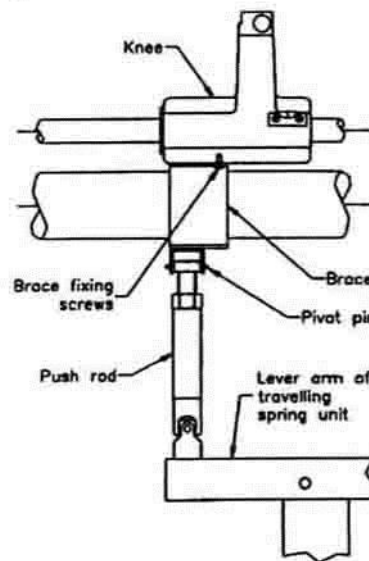

knee brace
depressing

* Remove the shipping pin and check that the Y micrometer is as free to move as the X micrometer when the XY stage is centralized. If any stiffness is noticed or if there is more resistance in one direction than the other, then advice should be sought from VACGEN.

* With the XY stage centralized, check that both lever arms are horizontal. Adjustments may be made to the push rods via the end fittings. Also check that full Y travel can be achieved without contact being made with the lever arm stops.

* Check that the Z travel can be achieved without the traveling unit coming to the end of its track.

* With the Z-slide at either extreme of travel, measure the height of the translator above the track at the outer end. Repeat this measurement when the travel is at the other extreme. A difference greater than 5mm may indicate that further adjustment is necessary. Consult the factory.

* The base of the end compensator and the track must be bolted firmly in position.

Caution. Protect the OMMAX and its compensation units from accidental knocks that could dislodge the push rods and over-stress the system flange.

A4. OPTION C: FIXED HORIZONTAL STAND, HSC

Description

The fixed stand comprises of a split tube clamp that is fixed to the support pillar of the OMNIAX at its normal center of gravity, and an adjustable length push rod which connects between this clamp and the floor mounting base plate.

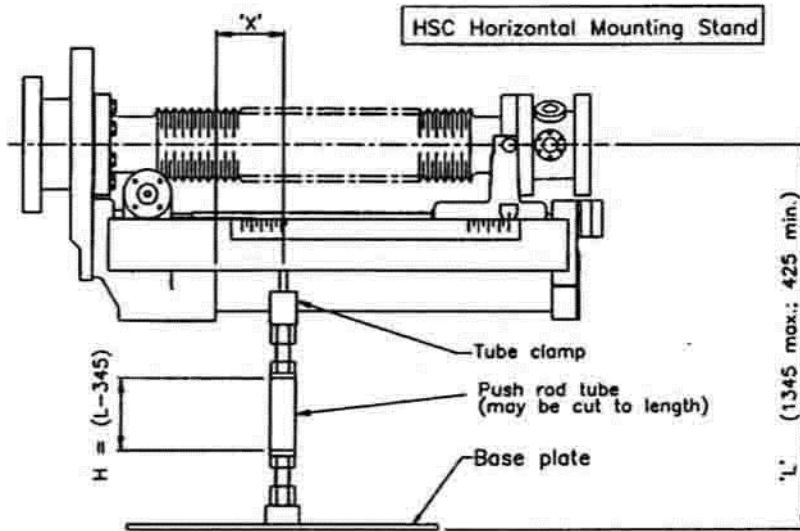

Clamp Position

Z Travel (mm)	Position of clamp, X (mm)
100	0
200	0
300	0
400	35
500	80
600	115
800	215
1000	310

Installation

- Establish the correct length, H, of the push rod tube from the measured value, L. ($H = L - 345$). The push rod end fittings should be adjusted to their mid position when making this calculation.
- Pull one of the end fittings from the tube and cut the tube back by the required amount. Replace the end fitting.
- Offer the OMNIAX to the chamber and, **WHILST SUPPORTING THE END CAREFULLY ON JACKS**, bolt to the chamber. Continue to support the device whilst the stand is maneuvered into position and the push rod fitted between the clamp and base plate.
- Bolt the base plate into position and remove the jacks.
- Protect the OMNIAX and its compensation unit from accidental knocks that could dislodge the push rod and over-stress the system flange.

APPENDIX B. STEPPER MOTOR CONNECTIONS

BI. OVERVIEW

Motors and encoders used in VACGEN equipment achieve their intended performance with VACGEN controllers (SDU, SMC or SMC-E) and no responsibility can be accepted should performance be inadequate when other controllers are used.

For attachment to VACGEN controllers, the motors (and encoders if applicable) can be supplied wired with suitable connectors. Otherwise, motors are supplied without connectors to allow connection to alternative drive and controller systems.

All motor variants are 4 phase, 8-lead hybrid stepper motors that can be wired up in most normal configurations as shown below. Some motor kits may include microswitches.

For motors fitted with incremental encoders, the VACGEN SMC-E range of controllers is required to provide passive feedback. If the motor has no encoder fitted, the controller cannot be used in the "Loop Active" mode. Note that encoders cannot be retrofitted to motors.

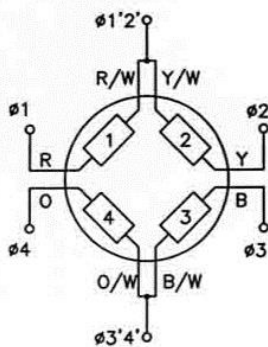

UNI-POLAR:
Use only where low torque at low speed is sufficient.

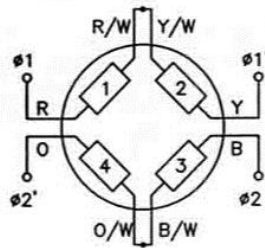

BI-POLAR IN SERIES
Provides high torque at low speed.

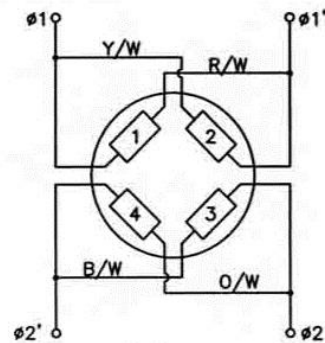

BI-POLAR IN PARALLEL
Provides moderate torque at low and high speeds.

Key to Colour Coding:

Wire colours as follows.

R - Red, W - White, Y - Yellow. B - Black, O - Orange, G - Green

Alternative motors may be used, with alternative colours. Refer to the following sections.

B2. MOTOR SPECIFICATION

Motor Type	Step angle	Rotor Inertia Tolerance	Resistance per Phase	Current per Phase	Inductance per Phase
23HS-108E	1.8 ^{o(1)}	5%	0.33	3.9A ⁽²⁾	0.38mH
23HS-309E	1.8 ^{o(1)}	5%	0.40	4.7A ⁽²⁾	0.84mH
23HS-409E	1.8 ^{o(1)}	5%	0.48	4.6A ⁽²⁾	1.00mH
34HS-109E	1.8 ^{o(1)}	5%	0.45	4.7A ⁽²⁾	1.30mH
34HS-209E	1.8 ^{o(1)}	5%	0.55	4.6A ⁽²⁾	2.50mH

Notes:

(1) Step angle quoted for full step drive. VACGEN controllers use half step drives with step angle being 0.9°.

(2) Limit the maximum current to the following values, determined by the drive used.

(Note that running at maximum current can cause motor to run hot and can give rise to resonance.)

* Maximum current/phase for unipolar drive = rated current.

* Maximum current/phase for bi-polar in series = 0.70 x rated current.

* Maximum current/phase for bi-polar in parallel = 1.4 x rated current.

B3. COLOUR CODING OF MOTOR WIRES

Key to Colour Coding:

R - Red, W - White, Y - Yellow, B - Black, O - Orange, G - Green

Alternative motors may be used. Wire colours as follows.

	As drawn	Alternative 1	Alternative 2
Phase 1	R	R	R
	R/W	B	Purple
Phase 1'	Y	R/W	Y
	Y/W	W	Blue
Phase 2	B	G/W	Pink
	B/W	B/W	Grey
Phase 2'	O	G	B
	O/W	O	W

B4. MOTOR WIRING DIAGRAMS

Caution: When wiring motors, care must be taken to make all connections secure. Failure to do so may result in disconnection during use and this can permanently damage the motor drive. For the same reason, never disconnect a motor from its drive unless the power has first been switched off.

Refer to previous section for colour coding of wires.

Series Motor Wiring

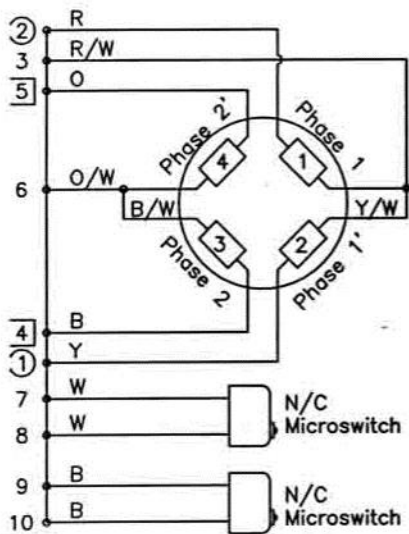

Parallel Motor Wiring

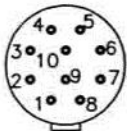
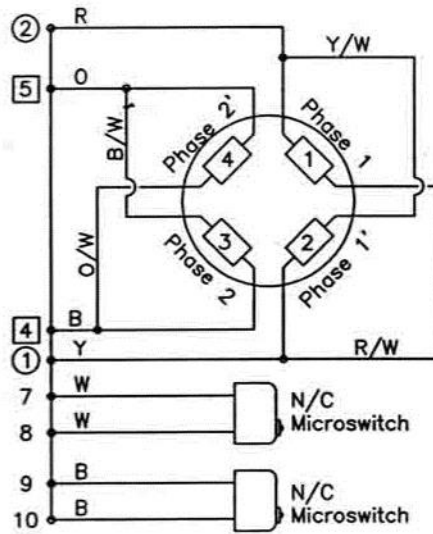

These diagrams show connections for compatibility with Vacuum Generators motor controllers.

Socket used is ref. XSOC24 (Series and parallel connection).

Series connection is preferred for high torque at low speed. Parallel connection is used for higher speed applications.

Where microswitches are not used, links must be made between pins 7 and 8, and between pins 9 and 10.

If the rotation direction is opposite to that required, reverse the connections on pins 1 and 2.

Twist together phase pairs to reduce electro-magnetic emission, i.e.: ① and ②, and ④ and ⑤.

Wiring diagrams for motors suitable for VACGEN Controllers

B5. ENCODER WIRING DIAGRAMS

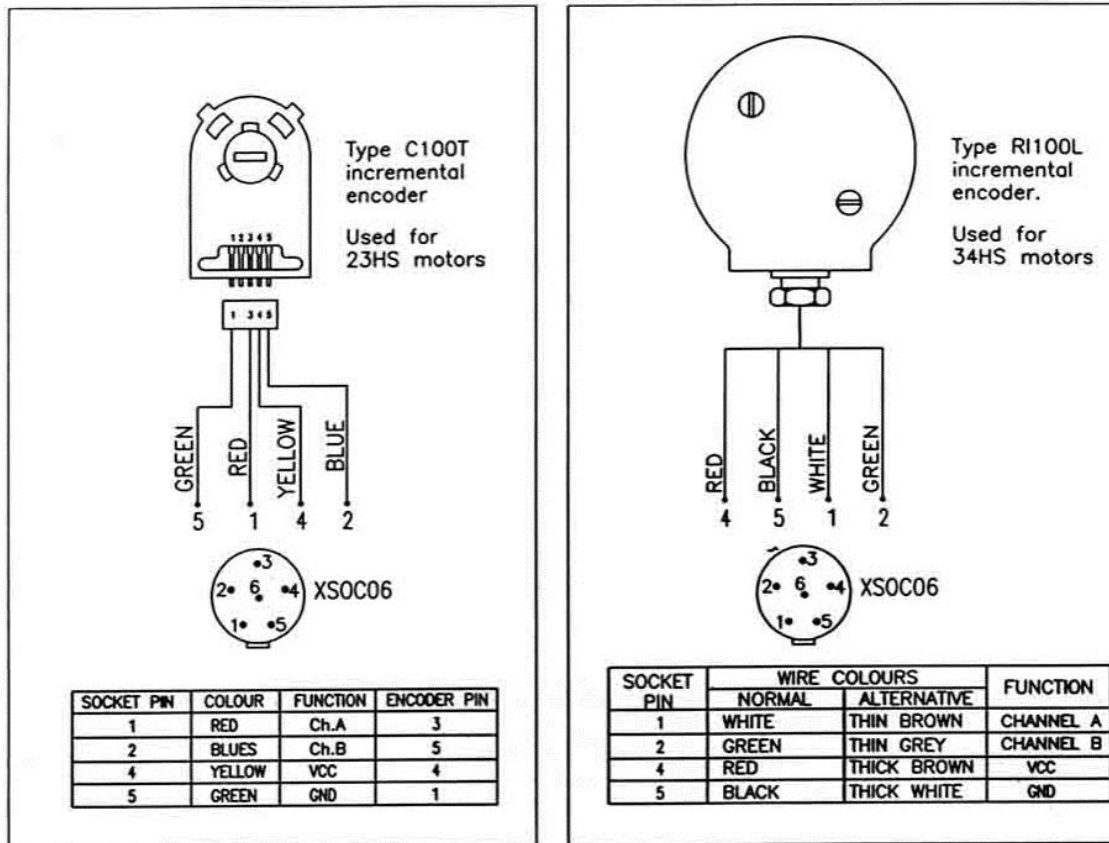

Wiring diagrams for incremental motor encoders

B6. MOTOR SPARES

Order Code	Description
ZSMPC3LH	Cable: Motor to SMC, SME-E or SDU controller.
DB08073	Cable: Encoder to SMC-E controller.
XSOC24	Connector socket. Fitted to motor lad or connection to VACGEN controllers.
XPLU11	Connector plug. Fitted to controllers for connection to XSOC24 motor socket.

APPENDIX C. HEATER AND VACGENCOUPLES

C1. DESCRIPTION

Sample heating is normally by either:

- * Resistance heating (HST option), or
- * Electron bombardment heating (FBH option).

These heaters are intended for mounting onto the standard range of VACGEN sample holders (e.g. SH1, SH1E50, SH2, SH2E50, SH2R64, SH2F, SH2RT, SM2T and SM2VT.)

Two VACGENcouples are provided with either heater module. These are available as either Type K (Chromel-Alumel) or Type N (Nicrosil-Nisil). Type N is recommended where low magnetic permeability is important. Temperature control is recommended, using:

- * the RHC controller for the HST and
- * the EBHC controller for the EBH

C2. WIRING DIAGRAMS

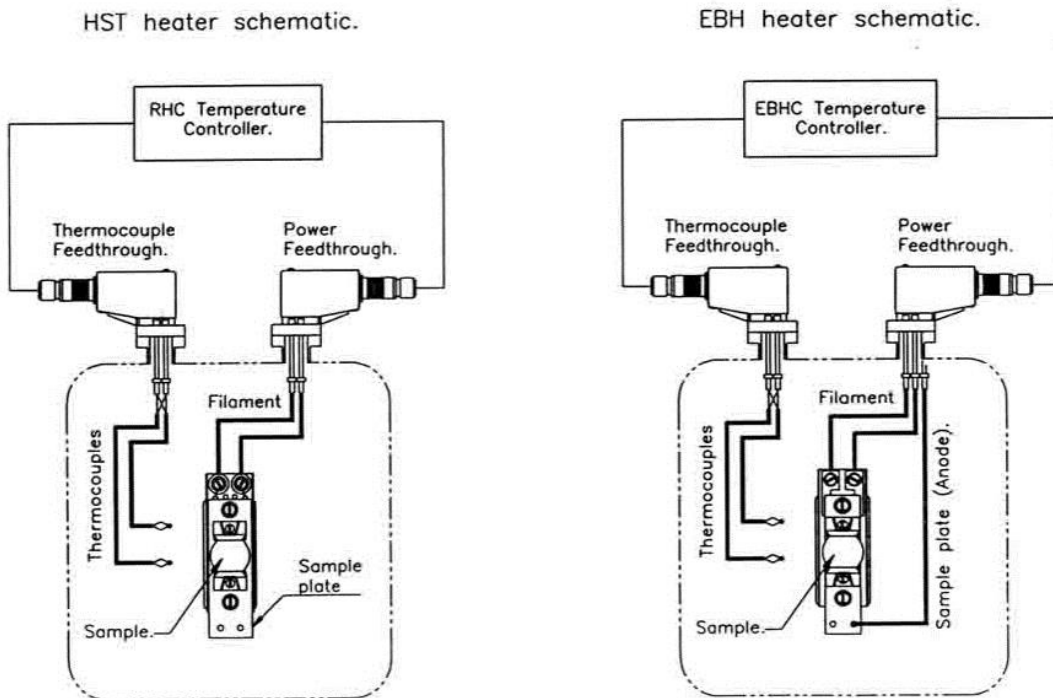

WARNING: It is very dangerous to leave feedthrough contacts isolated, especially during bakeout and when high voltages are present near to the sample. It is the responsibility of the user to be aware of electrostatic charge buildup and to provide suitable earthing.

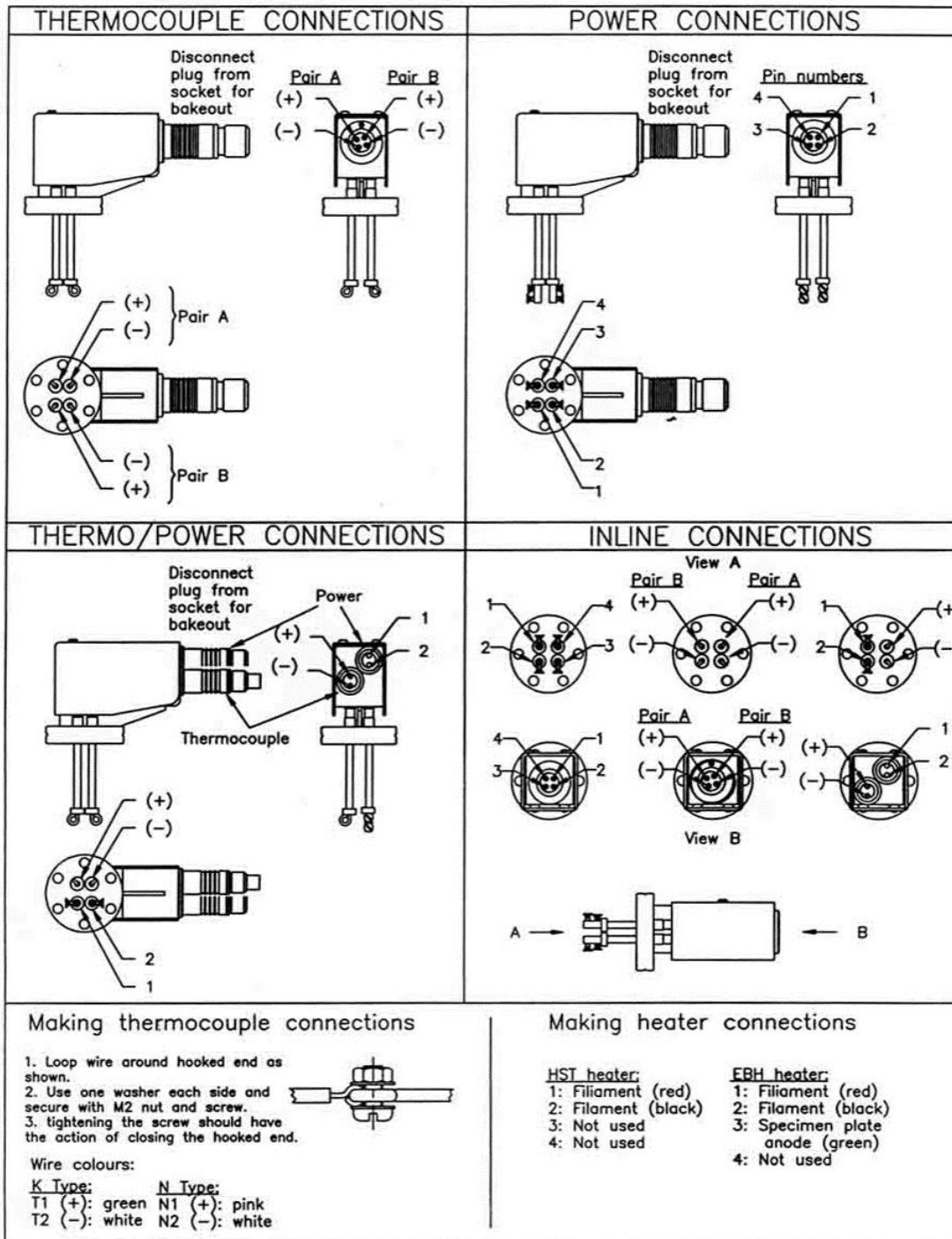

APPENDIX D. LIQUID NITROGEN COOLING

WARNING: VACGEN cannot advise on the safe use and handling of liquid gases which is entirely the responsibility of the user. The use of liquid nitrogen in confined spaces can be extremely dangerous as nitrogen gas levels can build up rapidly. Ensure that the area is well ventilated. Always wear insulated gloves and safety goggles when handling liquid gases and surfaces that may be cold.

D1. REQUIREMENTS

A supply of high purity nitrogen gas from a regulated supply.

A supply of liquid nitrogen.

A condenser coil, insulated open polystyrene dewar and connecting polythene tubes with insulation (These items are available from VACGEN as an accessory, order code ZLNHX).

D2. DESCRIPTION

Liquid nitrogen condensed from dry gas, enters and leaves the translator through liquid feedthrough connections. In-vacuum capillary tubing extends to the evaporator which should be mounted close to the sample position. The capillary tube is normally coiled to allow movement.

Conductive braid, electrically isolated from the evaporator, is supplied for mounting as near as possible to the sample.

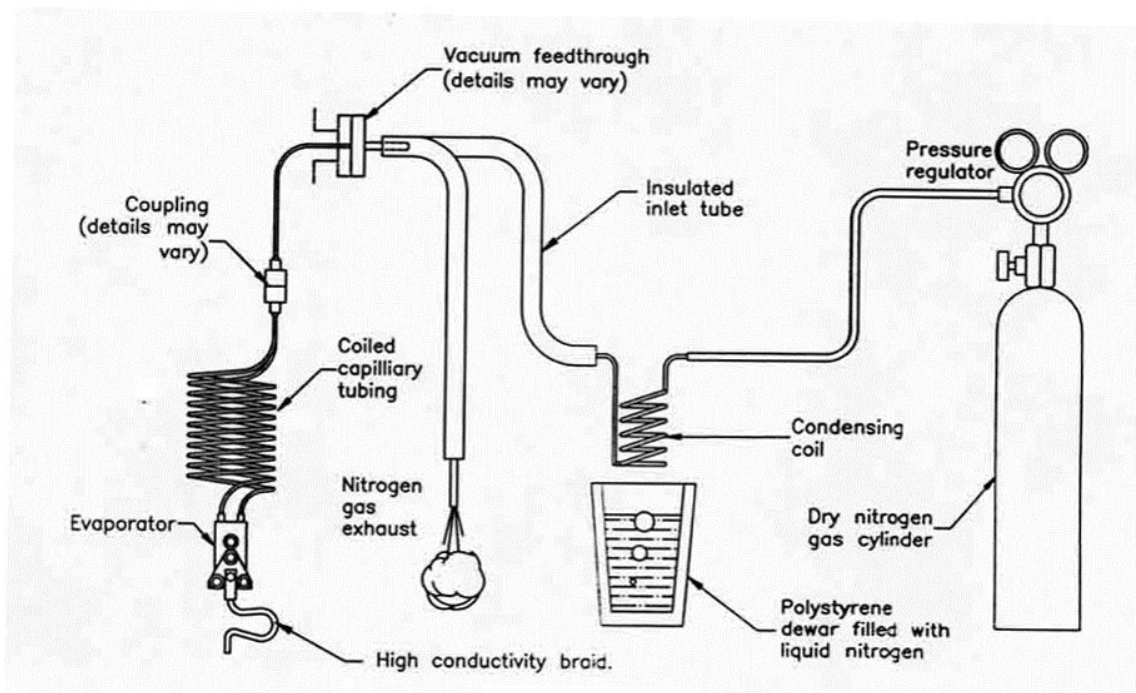

LIQUID NITROGEN COOLING SCHEMATIC

D3. SETTING UP

Position the copper condenser coil and polystyrene dewar as near as possible to the nitrogen entry feedthroughs. Using 6.35mm bore tubing, connect the regulator on the cylinder to the coiled end of the copper coil and secure with hose clips.

Connect the vertical end of the coil using 3mm bore tube to (either) feedthrough port. External insulating tube should cover the tube as completely as possible.

The outlet connection should be made to the other manipulator port. Ensure that the exhaust gas/liquid is well away from equipment that could be affected by moisture.

For horizontally mounted units a simple foil sheet should be fitted under the inlet 1 outlet connections to help to prevent condensation dripping onto the drive screw and bearing shafts.

D4. OPERATION

- a. Open the regulator to 0.5 bar to start a flow of gas through the system. Check that flow is coming from the system outlet pipe. Allow the gas flow to continue through the system for at least 2 minutes. This will purge the system of air to avoid formation of ice during cooling.
- b. Place the coil in the dewar and fill the dewar with liquid nitrogen. Always maintain at least 25 mm of liquid above the top coil.
- c. Increase the pressure to a maximum of 2 bar to start the cool-down cycle.
- d. Liquid nitrogen will start to emerge in droplets from the outlet pipe within 10 minutes.
- e. Reduce the gas pressure so that occasional droplets of nitrogen emerge. Excessive liquid mixed with the exhaust gas will reduce the cooling efficiency.
- f. Once the desired temperature has been reached the gas flow can be reduced further.
- g. On the completion of the cooling run, remove the copper coil from the dewar and allow the system to return to ambient temperature with a very gentle flow of nitrogen gas to prevent condensation.

D5. PERFORMANCE

The cooling performance will vary depending on many factors, including the nature of the sample, the sample mounting arrangements, radiated heat from the chamber, vacuum pressure and experimental conditions. The temperature will drop sharply once liquid has reached the evaporator, (when liquid droplets begin to emerge from the exhaust.) The temperature will continue to fall and stabilise after approximately 1 hour.

D6. BAKEOUT

Disconnect all plastic tubes from the liquid nitrogen feedthrough connections before commencing bakeout.

VACGEN
Maunsell Rd
Castleham Industrial Estate
East Sussex
TN38 9NN
England
Tel: +44 (0) 3424 851291
Fax: +44 (0) 1424 851489

E.C. Declaration of Incorporation
ref Dol-147 (VGF 4.06d Iss2)

We hereby declare that the following product range:

Part Codes:
Z Slides: MXZ100, MXZ1000
XY Slides: MT00B, MT108B, MT208B, MT211B
Motor Kits: MMOTZST, MT08X, MT08Y
Stands: MHSA, MHSB, MHSC

are, suitable for incorporation or assembly into a vacuum system or other machinery. These products may only be put into service if it has been verified that the system or machinery into which it is incorporated conforms to the provisions of the appropriate EU directives and with the limitations of the equipment specifications.

Applicable regulations:
89/392/EEC Version.93/68/EEC
Appropriate harmonised or national standards.

EN292-1
EN292-2

(Signed).....

Dr R J K Nicholson
Director of Development

Service and Repair Form

Declaration of Contamination of Equipment and Components

Servicing and repairs will only be carried out if the conditions for Servicing and Repair are complied with in full, according to the VACGEN Ltd. Conditions of Sale. A summary of these requirements are included on the inside front cover of the Operating Instructions. The manufacturer will refuse to accept any equipment without a signed declaration attached to the OUTSIDE of the packaging. This declaration can only be completed and signed by authorized and qualified staff.

1 Description of Equipment and Components

Equipment Type..... Model Number.....
 Serial Number..... Your Reference Number.....

2 **Reasons** **for**
return.....

3 Condition of Equipment

YES () NO () Toxic? YES () NO () Corrosive?
 YES () NO () Explosive? YES () NO () Biological Hazard?
 YES () NO () Radioactive? YES () NO () Other Harmful Substances?

Equipment and Components that have been contaminated, WILL NOT be accepted without written evidence of decontamination.

5 Contamination Materials

List all the substances, gases and by-products that may have come in contact with the equipment, giving trade name, manufacture, chemicals names or symbols.
 Please note that any of these listed, must be completely removed, so it is safe to handle and weld, without giving off health threatening gases. Please enter details below and/or attach data sheets

.....

6 Legally Binding Declaration

I hereby declare that the information supplied on this form is complete and accurate.
 There by stating that the goods offer no risk to health or safety

Organisation..... Name.....
 Country..... Job Title.....
 Post/ZIP code..... Telephone.....
 Email.....

Signature..... Date.....

Return goods to: Address at top
 Phone: (0) 1424 851291 Fax (0) 1424 851489 (Form VGF33)